

钟罩——圆形法兰、刚性连接 A 型 ROUND BELLHOUSINGS RIGID SIZE A

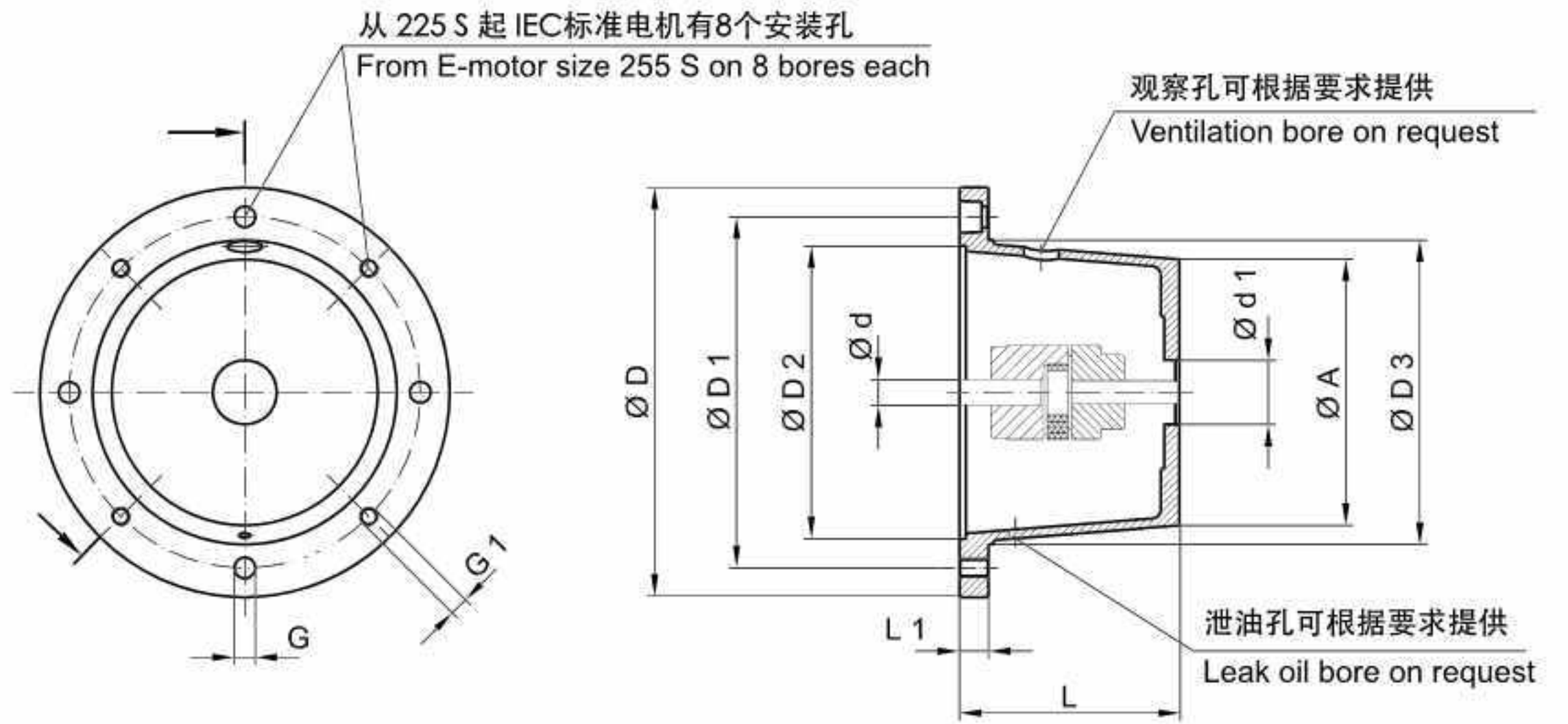

产品描述

- IEC 电机和液压泵之间的连接元件
- 库存有各种规格的钟罩, 适用于各种液压泵
- 两端安装法兰均经机加工
- 自动对中电机轴和泵轴
- 标准钟罩材质为铝

PRODUCT DESCRIPTION

- Connection elements between IEC motor and hydraulic pump
- Available for nearly all hydraulic pumps ex stock at short notice
- Both mounting sides are finished
- Centred motor shaft and pump shaft
- Standard bellhousings made of aluminium

用于 IMB5-IMB 35-IM V1 结构的电机

FOR ELECTRIC MOTORS FRAME IMB5-IMB 35-IM V1

IEC 电机型号 SIZE 电机轴 SHAFT (d x L)	电机功率 KW at n= 1500 min ⁻¹	钟罩 BELLHOUSING	弹性联轴器 ELASTIC COUPLING	钟罩支架 FOOT BRACKET	尺寸标注 / DIMENSIONS mm											
					电机侧 / MOTOR SIDE								泵侧 / PUMP SIDE			
					型号 / SIZE	型号 / SIZE	型号 / SIZE	∅ D	∅ D ₁	∅ D ₂	∅ D ₃	L	L ₁	G	G1	∅ A
71 (14 x 30)	0,25-0,37	PT 160/70/...	RE 19	PTFL 160	160	130	110	110	70	13	9	M8	103	22		
		PT 160/80/...							80	13					103	35
		PT 160/90/...							90	13					102	48
		PT 160/100/...*							100	13					104	50
80 (19 x 40) 90 S + L (24 x 50)	0,55-0,75 1,1-1,5	PT 200/90/...	RE 19	PTFL 200	200	165	130	145	90	16	11	M10	127	25		
		PT 200/100/...							100						127	25
		PT 200/110/...							110						126	45
		PT 200/124/...							124						125	50
100 L 112 M (28 x 60)	2,2-4	PT 250/124/...	RE 24	PTFS 250	250	215	180	190	124	18	14	M12	175	25		
		PT 250/135/...							135						174	50
		PT 250/160/...							160						176	50
		PT 250/174/...							174						175	58
132 S+M (38 x 80)	5,5-7,5	PT 300/144/...	RE 28	PTFS 300	300	265	230	234	144	20	14	M12	221	35		
		PT 300/155/...							155						220	55
		PT 300/168/...							168						218	65
		PT 300/186/...							186						217	65
		PT 300/198/...							198						216	75
160 M+L (42 x 110) 180 M+L (48 x 110)	11-15	PT 350/188/...	RE 38 (11-15 KW)	PTFS 350	350	300	250	260	188	26	18	M16	238	20		
	PT 350/204/...	204							237						48	
	18,5-22	PT 350/228/...	RE 42 (18,5-22 KW)						228						235	50
	PT 350/256/...	256							232						50	
200 L (55 x 110)	30	PT 400/204/...	RE 42	PTFS 400	400	350	300	300	204	26	18	M16	267	75		
		PT 400/228/...							228						263	75
		PT 400/256/...							256						258	75

钟罩——圆形法兰、刚性连接 A 型 ROUND BELLHOUSINGS RIGID SIZE A

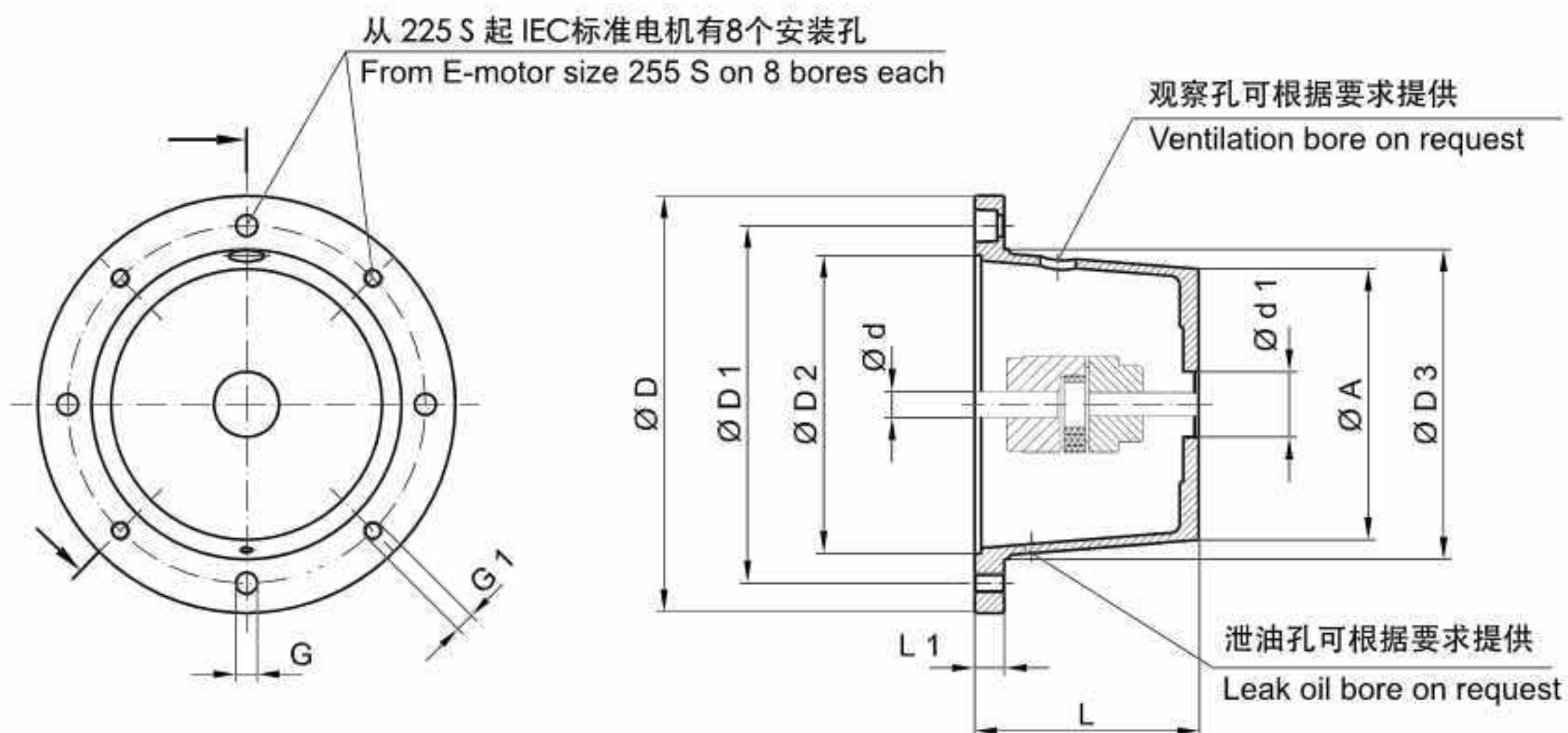

用于 IMB5-IMB 35-IM V1 结构的电机

FOR ELECTRIC MOTORS FRAME IMB5-IMB 35-IM V1

IEC 电机型号 SIZE 电机轴 SHAFT (d x L)	电机功率 KW at n = 1500 min ⁻¹	钟罩 BELLHOUSING	弹性联轴器 ELASTIC COUPLING	钟罩 支架 FOOT BRACKET	尺寸标注 / DIMENSIONS mm									
					电机侧 / MOTOR SIDE								泵侧 / PUMP SIDE	
					型号 / SIZE	型号 / SIZE	型号 / SIZE	∅ D	∅ D ₁	∅ D ₂	∅ D ₃	L	L ₁	G
225 S+M (60 x 140)	37-45	PT 450/234/...	RE 48	PTFS 450	450	400	350	350	234	26	18	M16	318	75
		PT 450/262/...							262				314	75
		PT 450/285/...							285				310	75
250 M (65 x 140)	55	PT 550/248/...	RE 55 (55 KW)	PTFS 550	550	500	450	450	248	26	18	M16	370	80
		PT 550/265/...							265				365	80
280 S+M (75 x 140)	75-90	PT 550/295/...	RE 65 (75-90 KW)	PTFS 550	550	500	450	450	295	26	18	M16	352	80
		PT 550/325/...*							325				345	120
315 S+M 315 L (80 x 170)	110-200	PT 660/310/...	RE 75 (110-132 KW)	PTFS 660	660	600	550	550	310	32	22	M20	410	120
		PT 660/330/...							330				405	120
		PT 660/345/...*							345				400	120
355 L/400 L (100 x 210)	250-400	PT 800/335/...	RE 90 (250 KW)	-	800	740	680	660	335	50	22	M20	490	125
		PT 800/365/...							365				425	125
		PT 800/395/...							395				416	125

钟罩的强度计算
Strength calculation of a bellhousing

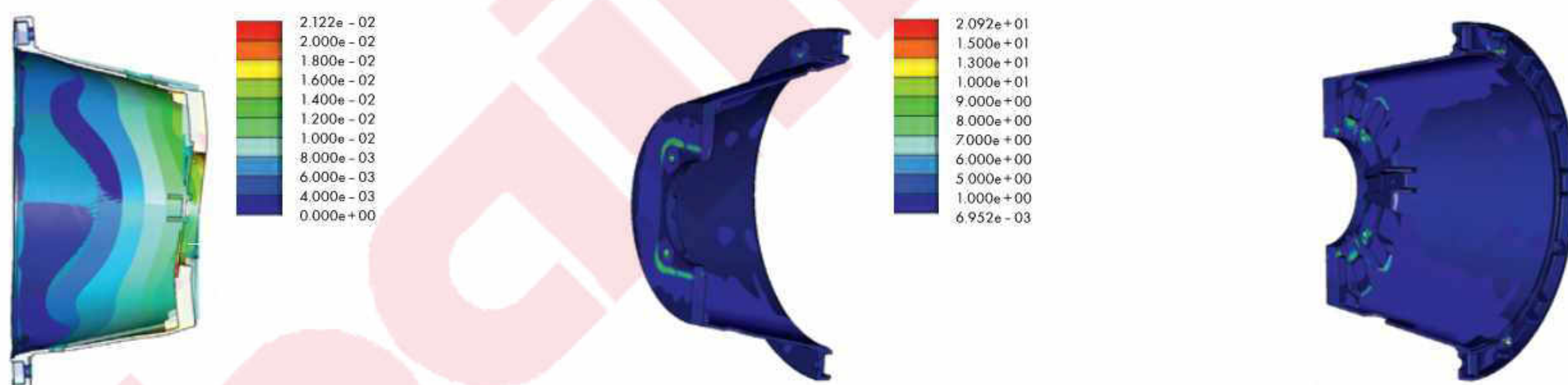

订货描述示例：钟罩

ORDERING CODE: BELLHOUSINGS

